

■電線包装用鉄製ドラム (JCS 8341 : 1993)

表 一般用鉄製ドラム寸法表

記号及び ドラム番号	つば径 D mm	胴径 d mm	外幅 W ₁ mm	内幅 W ₂ mm	軸穴径 h mm	巻始口			側板 山数	付属取り付け金具			参考			
						幅 H mm	長さ			巻始め口取り 付け金具数 本	巻終り端未取 り付け金具数 本	小割板止 ボルト数 本	概算質量		最大巻込質量	
							L ₁ mm	L mm					外輪補強無し kg	外輪補強有り kg	外輪補強無し kg	外輪補強有り kg
F11 - 1 2 3 4 5	1,400	800	880	750	105	80	370	530	28	4	2×6	2×6	115	135	3,000	3,500
	1,450												125	140		
	1,500												130	145		
	1,550												135	155		
	1,600												140	160		
F12 - 1 2 3 4 5	1,400	900	880	750	105	80	405	565	30	4	2×6	2×6	115	130	3,000	3,500
	1,450												120	140		
	1,500												125	145		
	1,550												135	150		
	1,600												140	160		
F13 - 1 2 3 4 5 6 7	1,500	1,000	880	750	105	80	465	625	30	4	2×6	2×6	125	145	3,000	3,500
	1,550												130	150		
	1,600												140	155		
	1,650												145	165		
	1,700												150	170		
	1,750												160	180		
	1,800												165	185		
F14 - 1 2 3 4 5 6 7	1,700	1,200	1,020	870	105	110	440	705	32	4	2×8	2×8	155	180	3,000	4,000
	1,750												165	190		
	1,800												170	195		
	1,850												175	205		
	1,900												185	215		
	1,950												190	220		
	2,000												200	230		
F15 - 1 2 3 4	1,900	1,400	1,020	870	105	110	555	820	32	4	2×8	2×8	180	205	3,000	4,000
	1,950												185	215		
	2,000												195	220		
	2,100												210	240		
F16 - 1 2 3 4	2,000	1,400	1,170	1,020	105	110	550	820	32	4	2×8	2×8	230	260	4,000	5,000
	2,100						245	280								
	2,200						265	295								
	2,300						280	315								
F17 - 1 2 3 4 5 6	2,100	1,600	1,170	1,020	105	110	570	835	36	4	2×8	2×8	245	275	4,000	5,000
	2,200								260				290			
	2,300								275				310			
	2,400								295				330			
	2,500								310				350			
	2,600								330				370			
F18 - 1 2 3 4	2,300	1,800	1,170	1,020	105	110	675	940	36	4	2×8	2×8	270	305	4,000	5,000
	2,400								285				320			
	2,500								305				340			
	2,600								325				360			

図1 一般用鉄製ドラム構造図 (F11~F15)

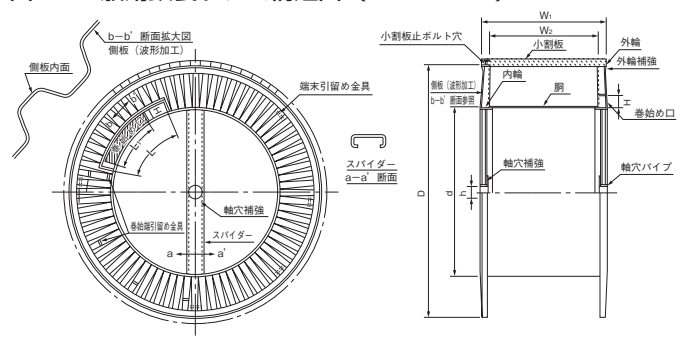

図2 一般用鉄製ドラム構造図 (F16~F18)

